

# CONGRATULATIONS ON YOUR NEW SCAN BUILT-IN STOVE

We are very happy that you have chosen a Scan-product, and we are sure that you will have years of pleasure from your purchase. To make the best possible use of your built-in stove, it is important that you follow our advice and instructions. Read through this Assembly and Instruction Manual carefully before you start to assemble your stove.





Scan 5001

# CONTENTS

<b>■ TECHNICAL DATA</b>	<b>4</b>
Installation .....	4
Safety .....	4
The clean air act 1993 and smoke control areas .....	4
Product registration number .....	4
Technical data and dimensions .....	5
Type plate .....	5
Dimensional drawing Scan 5001 .....	6
<b>■ ASSEMBLY</b>	<b>8</b>
Disposal of packaging .....	8
Fresh air intake .....	8
Closed combustion system .....	8
Load-bearing subsurface .....	8
Floor plate .....	8
Convection air .....	9
Existing chimney and pre-fabricated element chimney ..	9
Connection between built-in stove and steel chimney ..	9
Requirements for chimney .....	9
Balanced flue .....	9
Building in the stove in flammamable materials .....	9
Building in the stove at a fire wall .....	9
Positioning the stove at non-flammable materials .....	9
Trim .....	10
Minimum distance to flammable materials .....	10
Safety distance .....	10
Building into flammable material with fire wall .....	11
Cutout in the surround material .....	12
Clips for norway (large rooms) .....	13
Heat-storage system .....	13
Mounting of the heat shields/convection covers .....	14
Frames .....	18
Mounting of convection grate .....	20
<b>■ INSTRUCTIONS FOR USE</b>	<b>21</b>
Baffle plates .....	21
Ash container .....	21
Combustion air .....	21
<b>■ INSTRUCTIONS FOR HEATING</b>	<b>22</b>
Environmentally friendly operation .....	22
Lighting .....	22
Firing in the spring or autumn .....	22
Refuelling .....	23
Warning about over-firing .....	23
The function of the chimney .....	23
Using the stove in various weather conditions .....	23
General notes .....	23
Chimney fire .....	23
<b>■ HANDLING OF FUEL</b>	<b>24</b>
Selecting wood/fuel .....	24
Preparation .....	24
Storing .....	24
Moisture .....	24
Use of the following as fuel is illegal .....	24
Calorific value of the wood .....	24
<b>■ MAINTENANCE</b>	<b>25</b>
Sweeping the chimney and cleaning the stove .....	25
Checking the built-in stove .....	25
Servicing .....	25
Combustion chamber lining .....	25
Gaskets .....	26
Painted surfaces .....	26
Cleaning the glass .....	27
Disposal of stove parts .....	27
<b>■ TROUBLESHOOTING</b>	<b>28</b>
<b>■ WARRANTY</b>	<b>29</b>
<b>■ NOTES</b>	<b>31</b>

# TECHNICAL DATA

## INSTALLATION

---

- The house owner is responsible for ensuring that installation and assembly are in accordance with national and local building regulations as well as the information provided in this Assembly and Instruction Manual.
- When you install any kind of fireplace or stove, you must inform the local building and housing authorities. In addition you are obliged to have the installation inspected and approved by a local chimney sweep prior to commissioning.
- To ensure best-possible functionality and safety for your installation, we advise you to call a professional fitter. Your Scan Dealer will be able to recommend a qualified fitter in your area. For information on Scan Dealers, please go to [www.scan.dk](http://www.scan.dk).

## SAFETY

---

Any changes made to the product by the dealer, fitter or user could result in the product and safety functions not functioning as intended. The same applies to the fitting of accessories or extra equipment not supplied by Scan A/S. This could also be the case if parts that are necessary for the operation and safety of the stove are dismantled or removed.

## THE CLEAN AIR ACT 1993 AND SMOKE CONTROL AREAS

---

Under the Clean Air Act local authorities may declare the whole or part of the district of the authority to be a smoke control area. It is an offence to emit smoke from a chimney of a building, from a furnace or from any fixed boiler if located in a designated smoke control area. It is also an offence to acquire an "unauthorized fuel" for use within a smoke control area unless it is used in an "exempt" appliance ("exempted" from the controls which generally apply in the smoke control area).

The Secretary of State for Environment, Food and Rural Affairs has powers under the Act to authorize smokeless fuels or exempt appliances for use in smoke control areas in England. In Scotland and Wales this power rests with Ministers in the devolved administrations for those countries. Separate legislation, the Clean Air (Northern Ireland) Order 1981, applies in Northern Ireland. Therefore it is a requirement that fuels burnt or obtained for use in smoke control areas have been "authorized" in Regulations and that appliances used to burn solid fuel in those areas (other than "authorized" fuels) have been exempted by an Order made and signed by the Secretary of State or Minister in the devolved administrations.

- Further information on the requirements of the Clean Air Act can be found here: [www.smokecontrol.defra.gov.uk](http://www.smokecontrol.defra.gov.uk)
- Your local authority is responsible for implementing the Clean Air Act 1993 including designation and supervision of smoke control areas and you can contact them for details of Clean Air Act requirements"
- The secondary air valve has been modified, so that it does not close completely but has an opening corresponding to the position used at the lowest emission test.
- You can use any type of wood as fuel.
- This stove has been recommended as suitable for use in smoke control areas when burning wood.

## PRODUCT REGISTRATION NUMBER

---

All Scan wood-burning stoves are provided with a product registration number. Please make a note of this number at the rear page of this manual; you will always need to quote it when contacting your dealer or Scan A/S.

The product registration number is placed loose in the fireplace.

### Product registration number

SCAN 5001  
- SCAN 5001

**206A1X0032**

2 / 109915



206A1X0032

## TECHNICAL DATA AND DIMENSIONS

Materials	Steel plate Cast iron Galvanised sheet Chamotte
Surface treatment	Senotherm
Max. log length	30 cm
Weight Scan 5001	105 kg
Weight Scan 5001 w/heat shield	122 kg
Flue conn. piece internal diameter	144 mm
Flue conn. piece external diameter	150 mm
Approval type	Intermittend*

\* Intermittent operation in this context means normal use of a built-in stove. In other words, you should let the fire die down until only the embers are left before refuelling.

This built-in stove is produced in accordance with type approval for the product, which also covers the product's Assembly and Instruction Manual.

The Declaration of Performance (DoP) is available from [www.scan.dk](http://www.scan.dk)

### Tested in accordance with EN 13229

CO Emission at 13% O <sub>2</sub>	0,09	%
CO Emission at 13% O <sub>2</sub>	1082	mg/Nm <sup>3</sup>
Dust @ 13% O <sub>2</sub>	16	mg/Nm <sup>3</sup>
No <sub>x</sub> @ 13% O <sub>2</sub>	106	mg/Nm <sup>3</sup>
Efficiency	84	%
Energy efficiency index	112,8	
Energy efficiency class	A+	
Nominal output	5,0	kW
Chimney temperature EN 13229	227	°C
Temperature in flue conn. piece	272	°C
Amount of smoke	3,9	g/sec
Negative pressure EN 13229	12	Pa
Recommended negative pressure in flue connecting piece	16-20	Pa
Required combustion air supply	10-25	m <sup>3</sup> /h
Fuel	Wood	
Fuel consumption	1,4	kg/h
Amount of fuel required to light.	1,5	kg
Amount of fuel, max.	2,4	kg

## TYPE PLATE

All Scan built-in stoves are fitted with a type plate that specifies the approval standards and the distance to flammable materials.

The type plate is placed loose in the fireplace.

<b>Scan 5001</b>				
Freestanding room heater fired by solid fuel				
<b>Standard:</b>		<b>EN 13229</b>	<b>DoP 95001600</b>	
Minimum distance to combustible materials Side: 400 mm - Back: 400 mm - Front: 800 mm				
Minimum distance to firewall See assembly- and instructions manual				
The appliance can be operated in a shared flue.				
CO emission at 13% O <sub>2</sub> :		0,09%	1082 mg/Nm <sup>3</sup>	
Dust at 13% O <sub>2</sub> :			16 mg/Nm <sup>3</sup>	
Flue gas temperature:			227°C	
Nominal heat output:			5 kW	
Efficiency:			83,8%	
Fuel type:			Wood	
Operation type:			Intermittent	
Reaction to fire:			A1	
Country	Classification	Certificate/Standard	Approved by	
EUR	Intermittent	EN 13229	SZU	
Norway		NS 3058	Teknologisk Institut	
Germany	Stufe 2	1. BlmSchV		
Follow assembly- and instructions manual. Use only recommended fuels. Montage- und Bedienungsanleitung beachten. Verwenden Sie nur empfohlene Brennstoffe.				
1000	Scan A/S	DK 5492 Vissenbjerg	07-2017	

Type plate

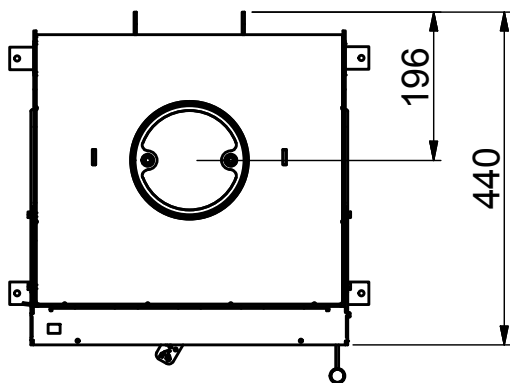
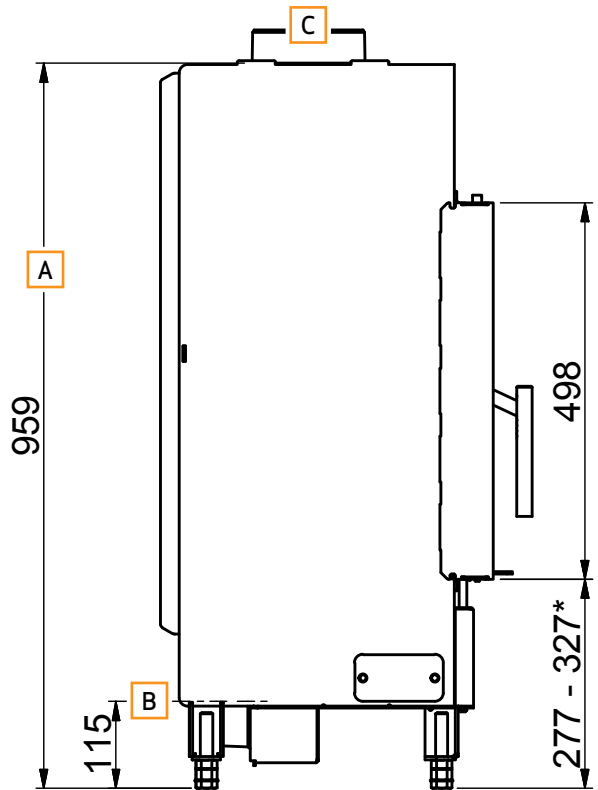
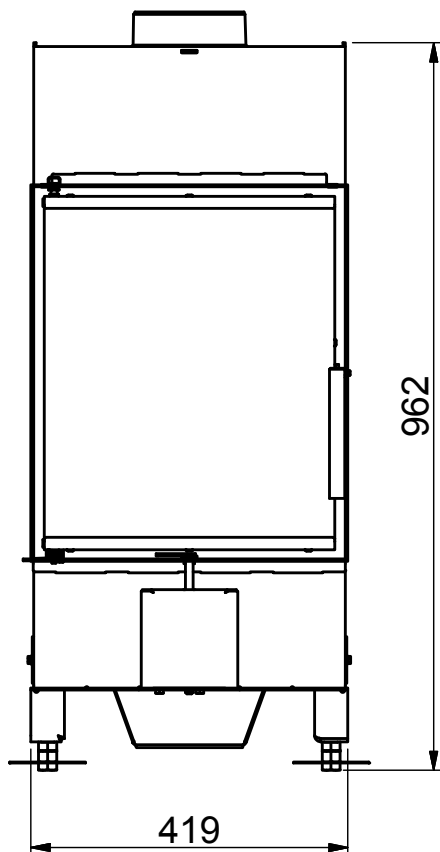

- A** Height to the beginning of flue connecting piece at top outlet
- B** Centre of fresh air intake - Inside measure: 103 mm, Outside measure: 120 mm
- C** Flue conn. piece - Inside measure: 132 mm, Outside measure: 149 mm

All measures are in mm

\*NB - remember to check the distance to flammable materials.

DIMENSIONAL DRAWING SCAN 5001, WITH HEAT SHIELD TO FIRE WALL (ACCESSORY)

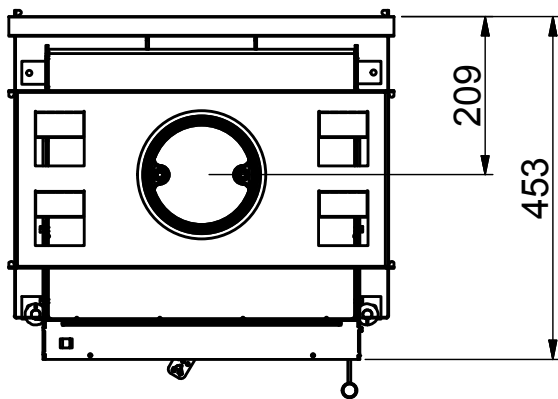
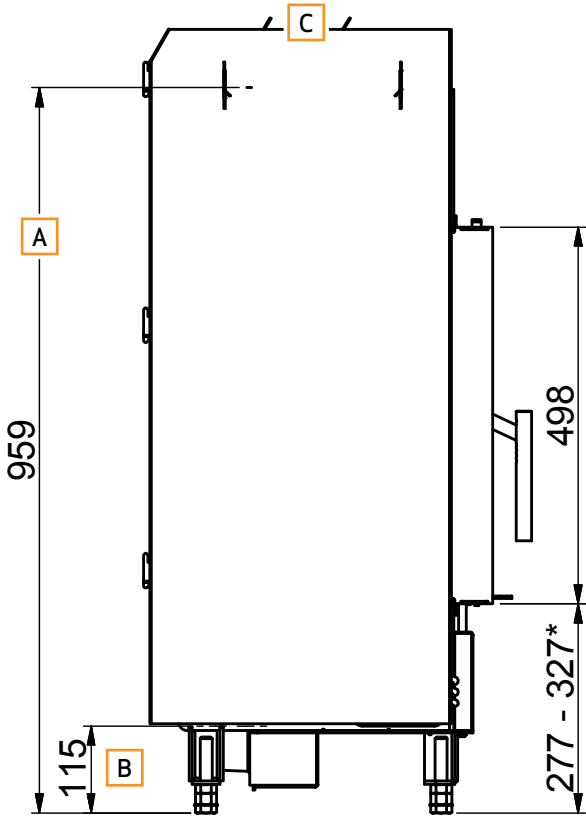
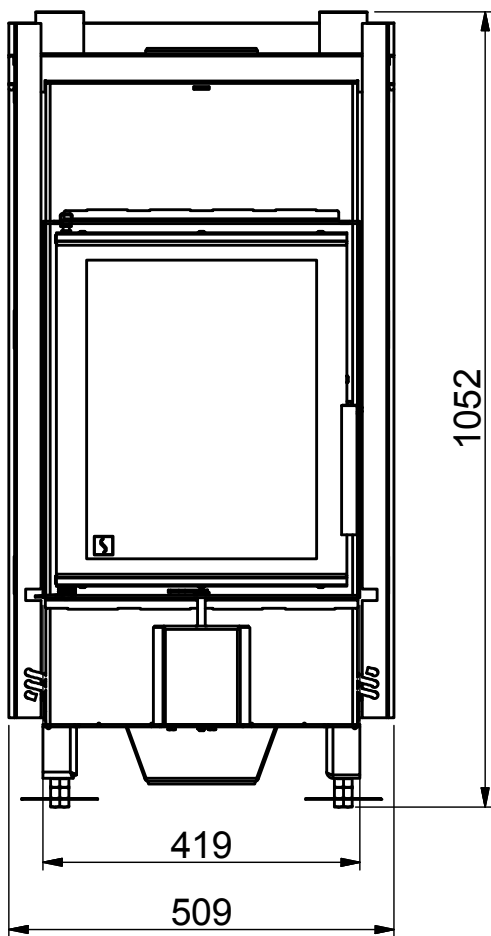

- A** Height to the beginning of flue connecting piece at top outlet
- B** Centre of fresh air intake - Inside measure: 103 mm, Outside measure: 120 mm
- C** Flue conn. piece - Inside measure: 132 mm, Outside measure: 149 mm

All measures are in mm

\*NB - remember to check the distance to flammable materials.

# ASSEMBLY

## DISPOSAL OF PACKAGING

---

Your Scan built-in stove may come supplied with the following packaging:

Wood packaging	The wood packaging can be reused and after final use can be incinerated as a CO <sub>2</sub> neutral product or sent for recycling.
Flamingotop	Send for recycling or waste disposal
Foam	Send for recycling or waste disposal
Plastic bags	Send for recycling or waste disposal
Stretch/plastic film	Send for recycling or waste disposal

## FRESH AIR INTAKE

---

In a well-insulated house the air used for the combustion process has to be replaced. This particularly applies to houses with mechanical ventilation. There are different ways of making sure that air is exchanged. The most important thing is to ensure that there is a supply of air to the room where the built-in stove is located. The external wall vent must be located as close to the stove as possible, and you must be able to close it when you are not using the stove. National and local building regulations must be followed with regard to connection of a fresh air intake.

The diameter of the connection piece for fresh air is 120 mm. If you want to use a 100 mm connection tube you can mount a gasket on the outside of the tube before mounting the tube inside the connection piece.

## CLOSED COMBUSTION SYSTEM

---

You should use the closed combustion system for the built-in stove if you live in a newly-built, airtight home. External combustion air is connected through a ventilation pipe via the wall or floor.

It must be possible to shut off the ventilation pipe with a valve, when the stove is not in use. Minimum  $\varnothing$  100 mm ventilation pipe, maximum length: 6 metres with a maximum of one bend. We recommend smooth steel pipes.

If you want external combustion air at the rear, you must close the hole in the bottom with the dismantled cover plate.

**NOTE:** if the stove has a fresh air connexion or closed combustion, the ventilation pipe must be open, when the stove is in use!

## LOAD-BEARING SUBSURFACE

---

All items in our product range come under the category of lightweight fireplaces and stoves and do not normally require any reinforcement of the beam structure. They can be positioned on ordinary beams/floor.

You should of course make sure that the subsurface on which the stove is positioned can indeed support the weight of the stove and, where applicable, a steel chimney, if you have opted for this solution.

## FLOOR PLATE

---

If you are placing the stove on a flammable floor, you must comply with the national and local regulations on the size of any non-flammable subsurface required to cover the floor around the stove.

Your local Scan dealer can advise you on regulations concerning protection of flammable materials in the vicinity of your stove.

The floor plate's function is to protect the floor and flammable material against any sparks that may occur.

## CONVECTION AIR

---

The covering must contain holes for convection air. Convection means that there is an air circulation ensuring that the heat is equally distributed in the room. It is important the demands concerning convection areas are observed.

- Min. area for ingoing convection air: 500 cm<sup>2</sup>
- Min. area for outgoing convection air: 750 cm<sup>2</sup>

If there is not enough convection air, the covering may be damaged. Convection air grids are available as an accessory.

## EXISTING CHIMNEY AND PRE-FABRICATED ELEMENT CHIMNEY

---

If you intend to connect your stove to an existing chimney, it makes sense to contact an authorised Scan dealer, or a local chimney sweep, for advice. These experts will also let you know if your chimney needs renovating.

- When connecting a pre-fabricated element chimney, follow the manufacturer's connection instructions for the relevant chimney type.

## CONNECTION BETWEEN BUILT-IN STOVE AND STEEL CHIMNEY

---

Your Scan dealer, or local chimney sweep, can advise you on choosing a make and type of steel chimney. This ensures that the chimney will match your wood-burning stove. As a general rule, the length of the chimney should not be less than 3.5 metres, measured from the top of the built-in stove. Specific weather or installation conditions might require a different length.

- Choosing the wrong length or diameter of steel chimney could impair functionality.
- Always comply exactly with the instructions provided by the steel chimney supplier.

## REQUIREMENTS FOR CHIMNEY

---

The chimney must have a minimum internal diameter of 148 mm and have a T400 designation, with G for the soot fire test.

If you opt to connect the stove with an elbow pipe, you should use a curved elbow, as this gives a better draught.

If you connect the stove with a sharp elbow pipe, the cleansing lid must be placed in the vertical part so that the horizontal part can be cleaned through here.

The requirements to the chimney and the flue pipe in terms of safety distances must be met.

## BALANCED FLUE

---

If the stove is connected with a balanced flue, we recommend the use of a 100 mm Lindab tube and a chimney length of min. 4.5 m.

## BUILDING IN THE STOVE IN FLAMMAMABLE MATERIALS

---

The stove is NOT to be built into flammable materials without the use of a fire wall and heat shields!

## BUILDING IN THE STOVE AT A FIRE WALL

---

We refer to the dimensional sketches on page 7.

## POSITIONING THE STOVE AT NON-FLAMMABLE MATERIALS

---

When bricking up/constructing a non-combustible covering, the distance to the stove must be min. 10 mm.

## TRIM

---

The trim is mounted, when the surfaces of the covering are finished.

## MINIMUM DISTANCE TO FLAMMABLE MATERIALS

---

Distance to side: 400 mm - back: 400 mm - glass: 800 mm.

You should however assess whether furniture or other items might become excessively dry due to being too close to the stove.

## SAFETY DISTANCE



---

European, national and local regulations concerning safety distances for wood-burning stoves must be complied with.

## BUILDING INTO FLAMMABLE MATERIAL WITH FIRE WALL

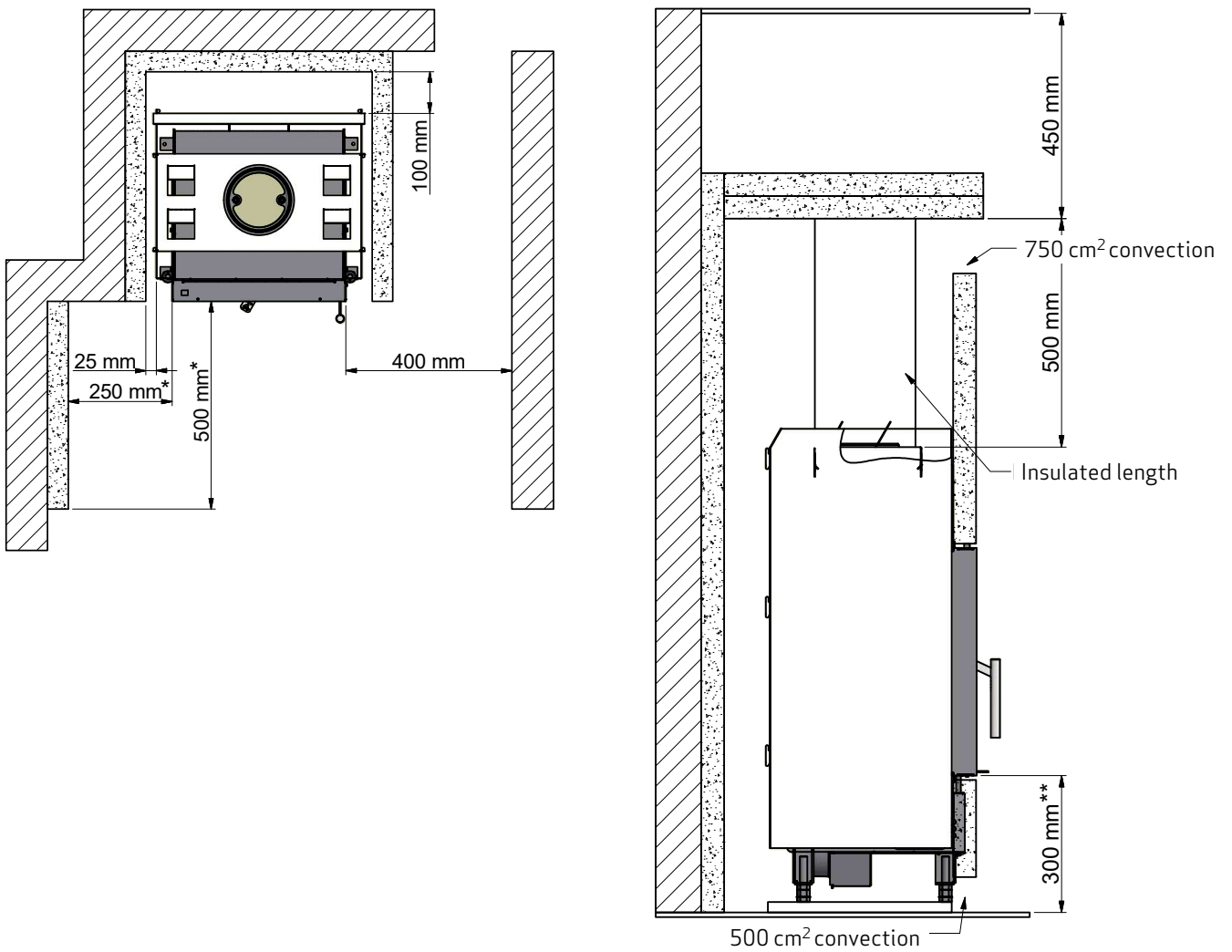
Building in the Scan 5001 with radiation shields against a flammable wall protected by a fire wall.



-  Flammable material
-  Fire wall, e.g. 50 mm Jøtul Firewall, 110 mm brick or other material with corresponding fireproof and insulating abilities

All distances are in mm.

All distances are minimum distances

Distance to furniture: 800 mm. from glass

\* Distance to glass

\*\* Distance to flammable floor

## CUTOUT IN THE SURROUND MATERIAL

---

If you want to build in the insert so that the surround is flush with the insert's door, it may be necessary - according to the thickness of the material - to make a cut in the material to allow space for the box on the front.

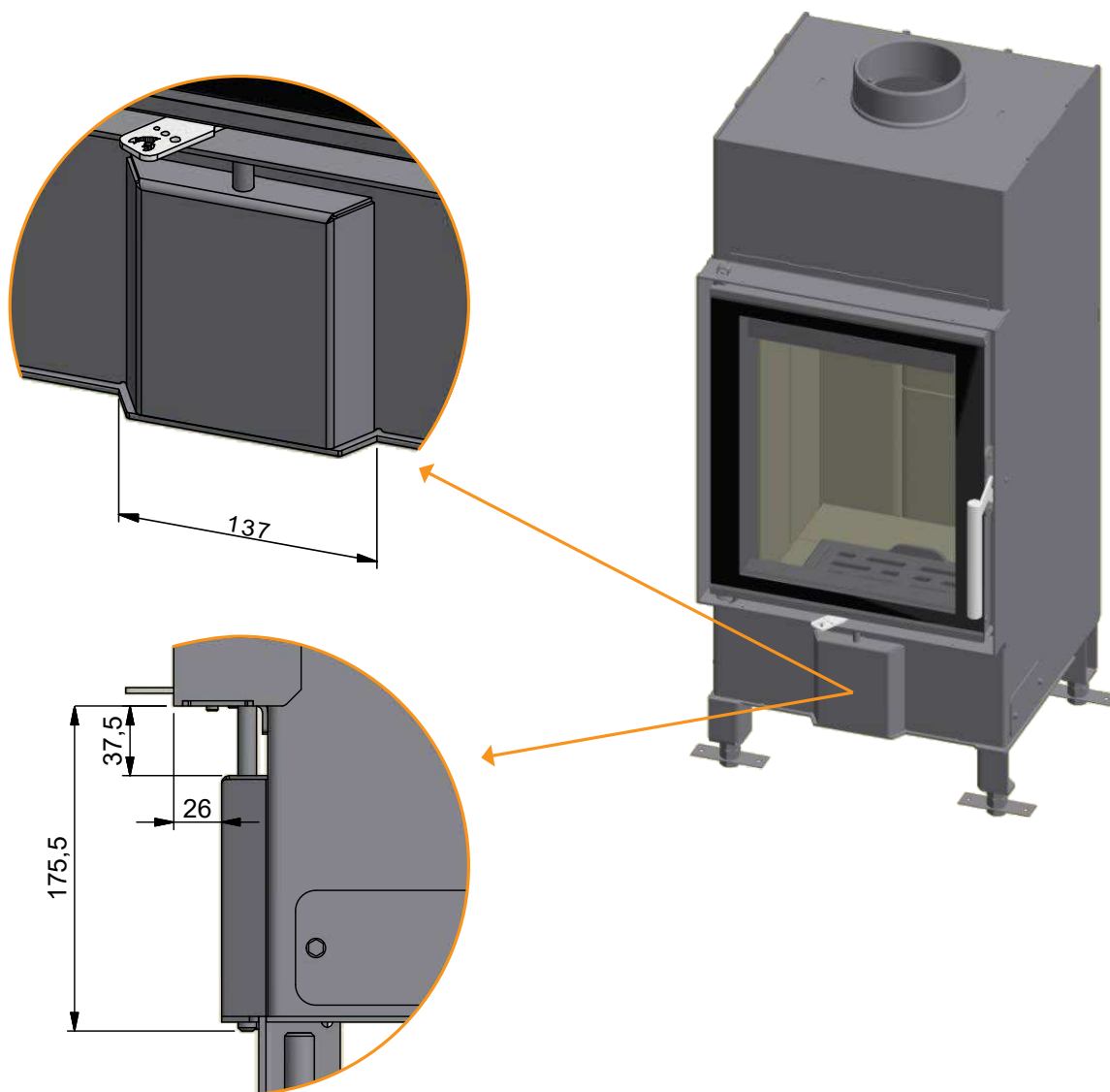

## CLIPS FOR NORWAY (LARGE ROOMS)

NB: Norway only!

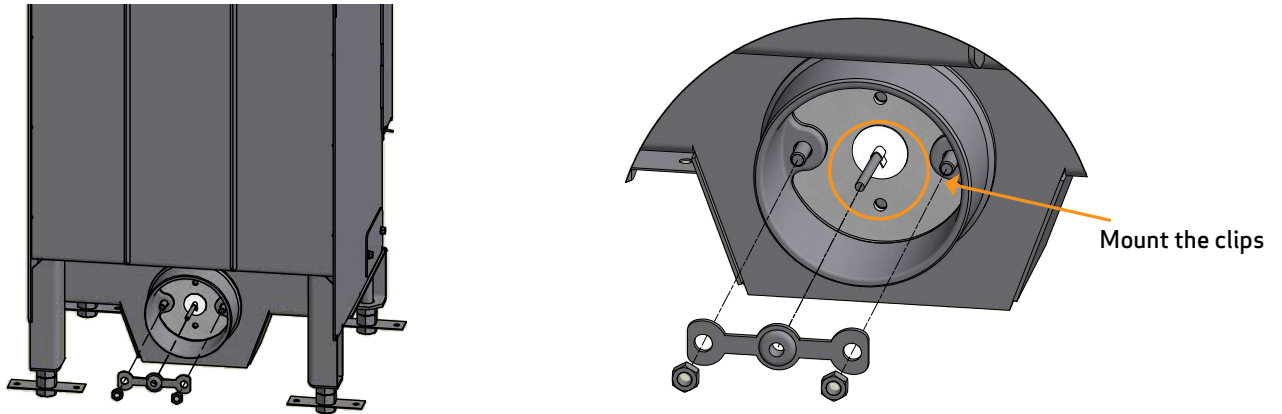

## HEAT-STORAGE SYSTEM (ACCESSORY)

Heat-storage stones are made from a special material with a high heat capacity. The stones are heated when the stove is on, re-releasing heat once it is off. This extends the time over which the stove remains warm.

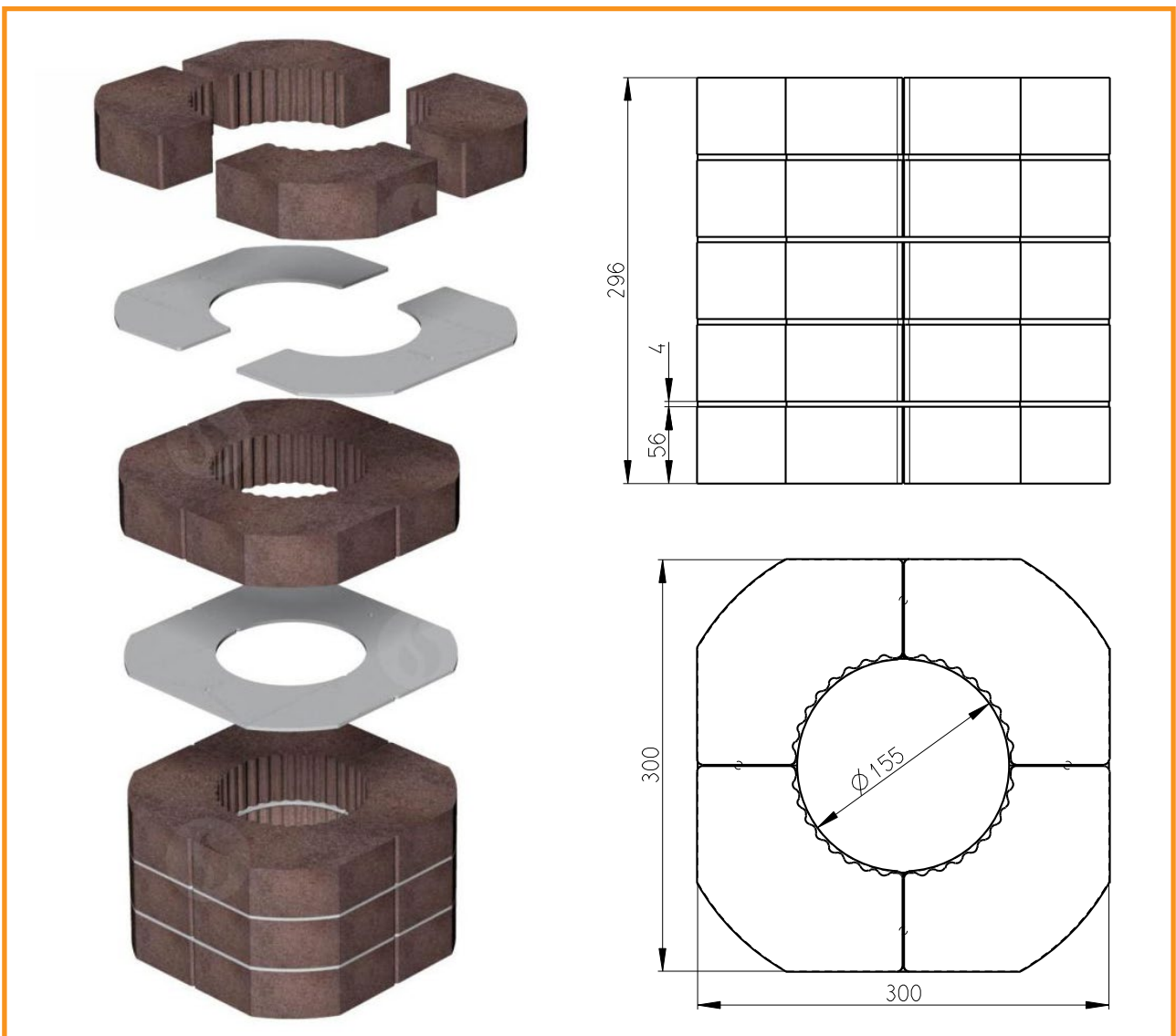

## MOUNTING OF THE HEAT SHIELDS/CONVECTION COVERS (ACCESSORY)

---

- 1 Place the heat shield on top of the built-in stove.

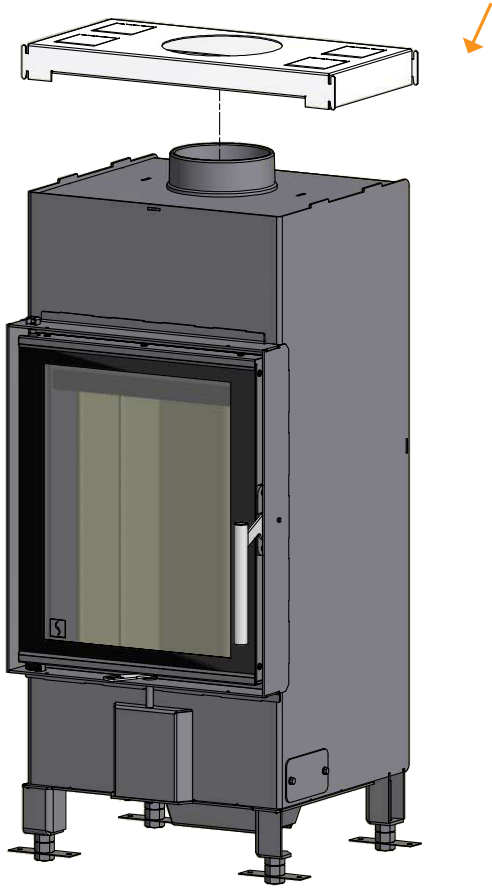

## MOUNTING OF THE HEAT SHIELDS/CONVECTION COVERS (ACCESSORY)

---

2

Mount the strings on both heat shields.

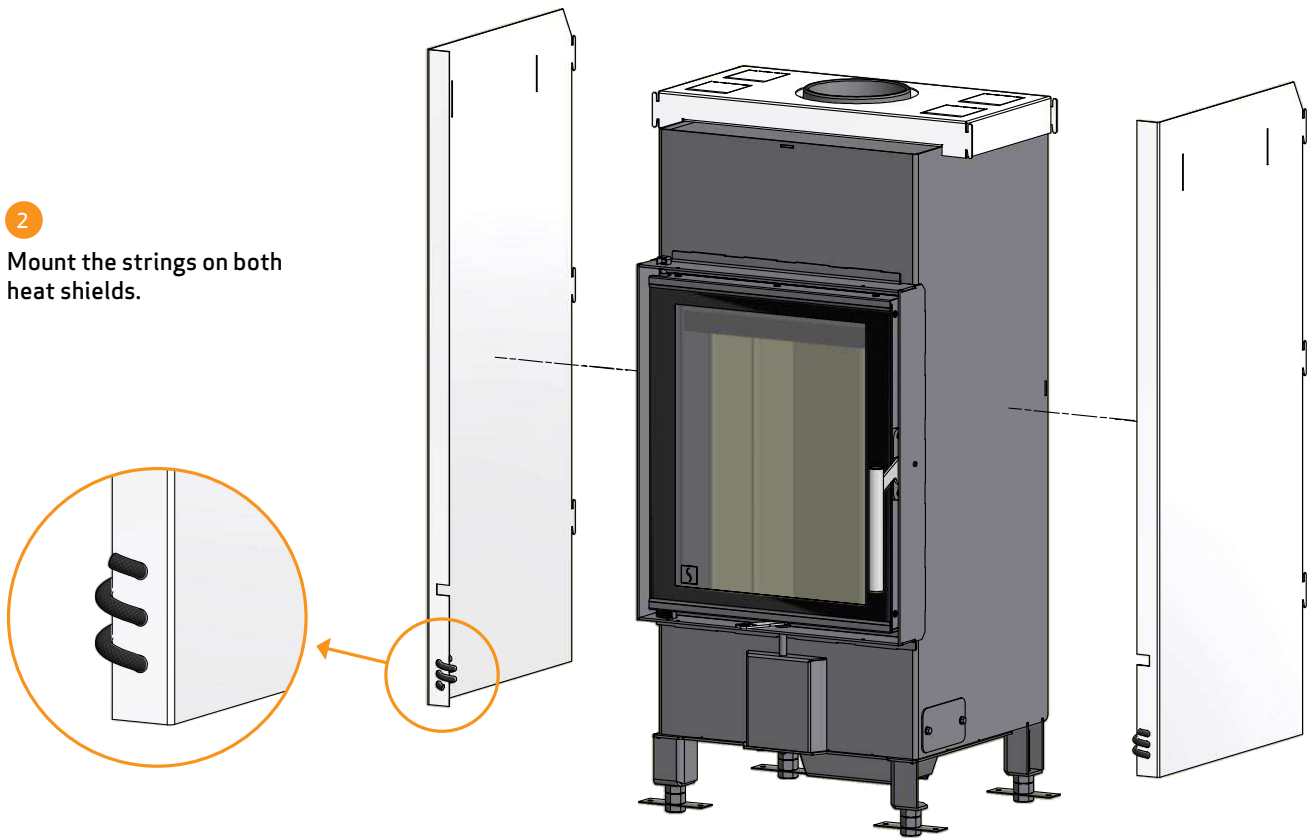

3

First mount the lateral heat shields on the stove and then the rear heat shield.

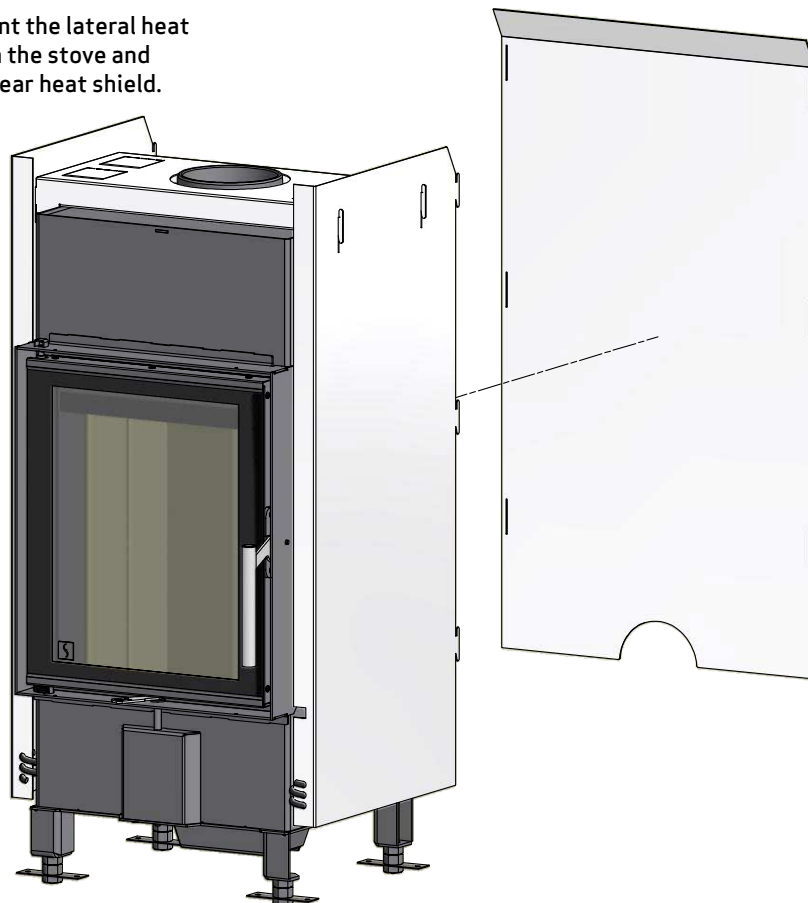

## MOUNTING OF THE HEAT SHIELDS/CONVECTION COVERS (ACCESSORY)

---

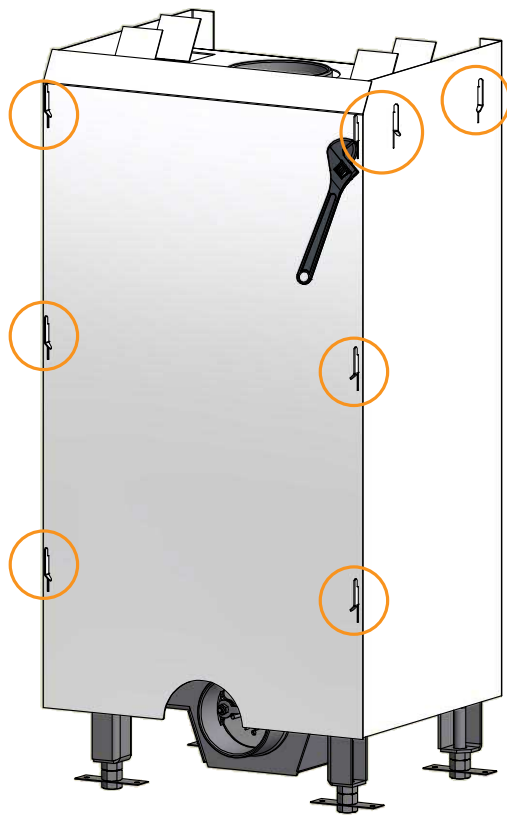

4

Fasten the heat shields (sides and rear) by bending slightly the splits with an adjustable spanner..

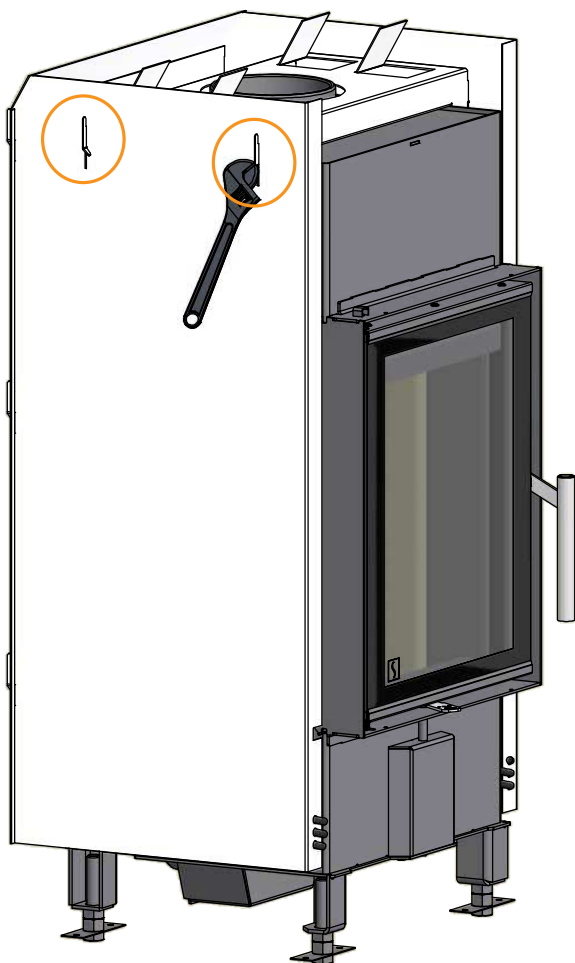
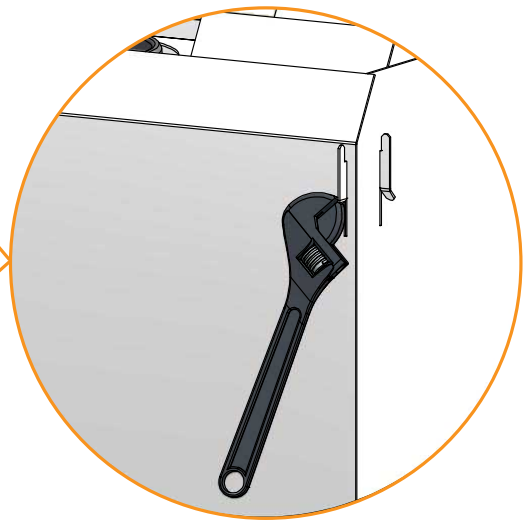

5

**IMPORTANT:** Open the four valves in the top with a flat-head screwdriver. The opening should be approx. 55 mm.

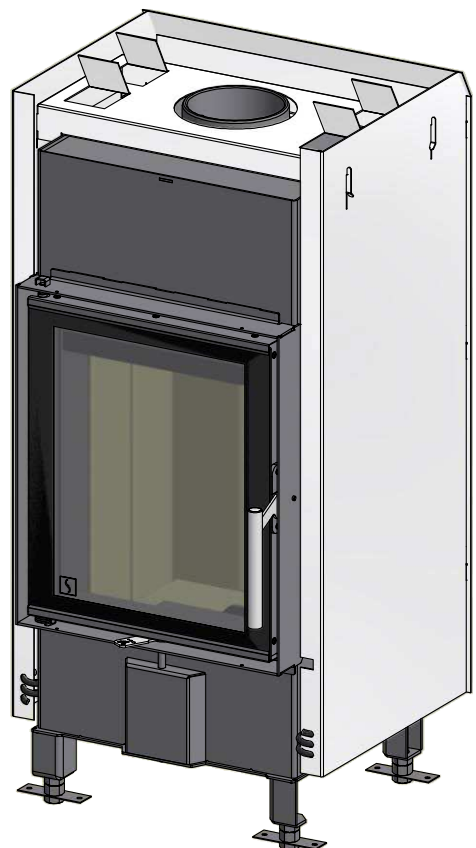
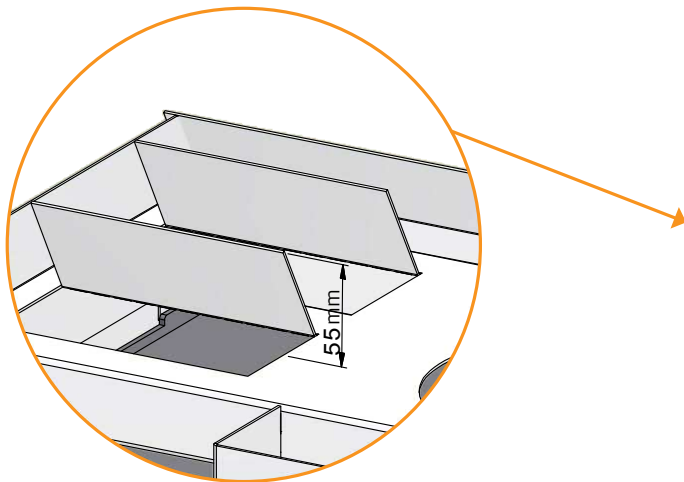
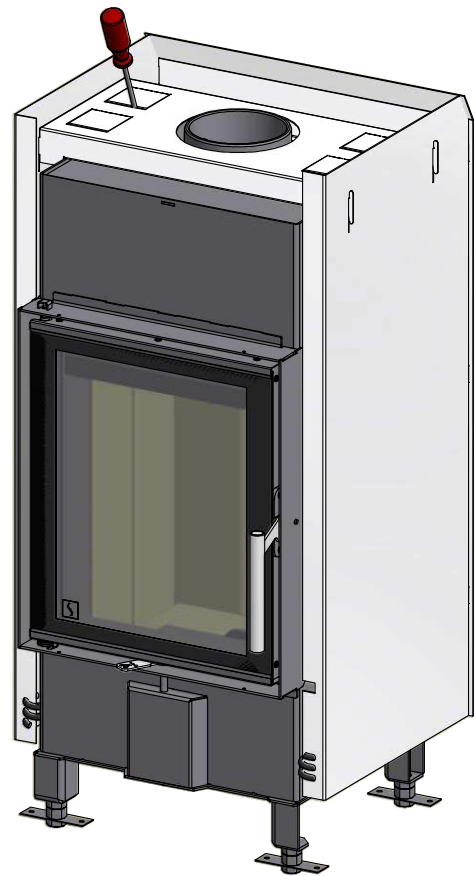
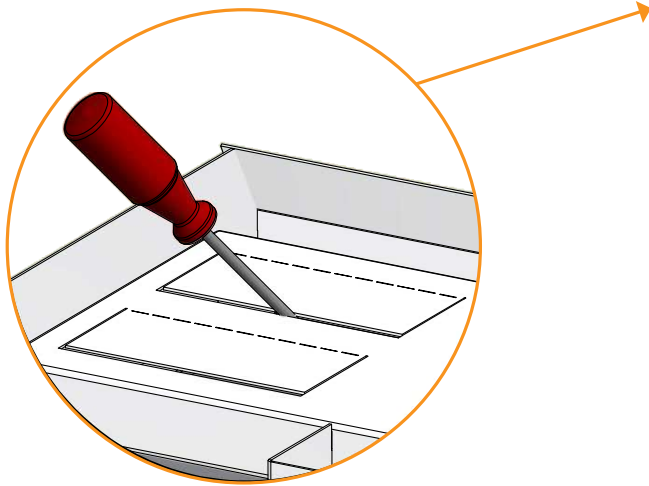

FRAMES (ACCESSORY)

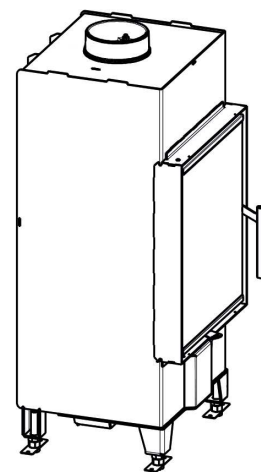
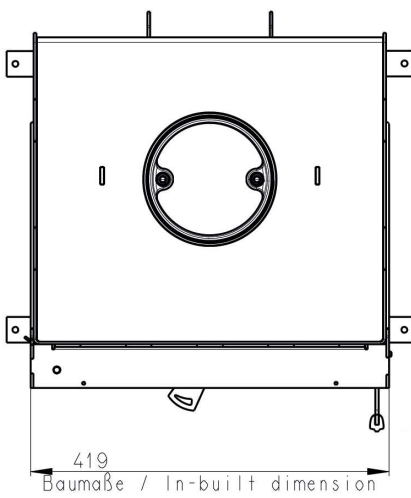
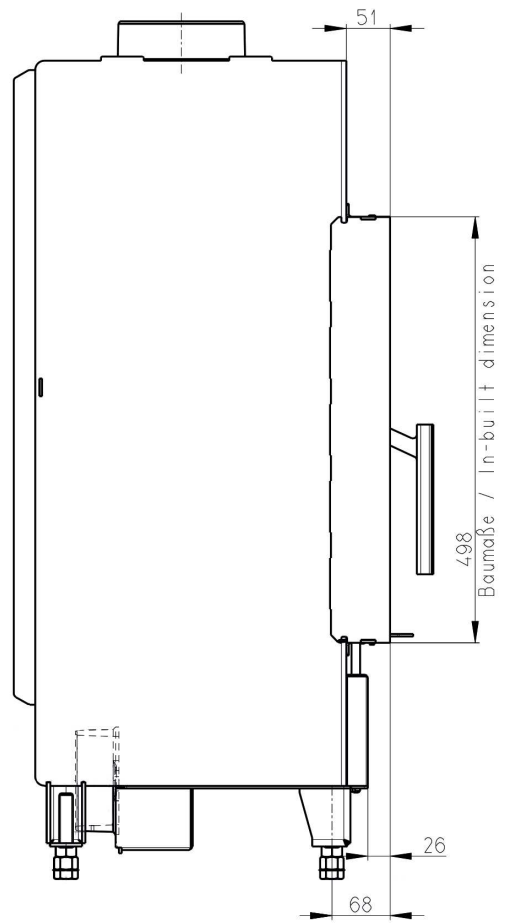
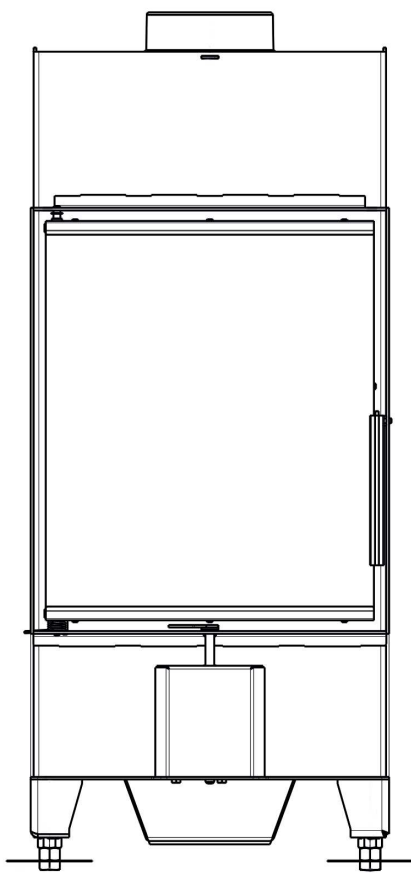

FRAMES (ACCESSORY)

Item # 50052619

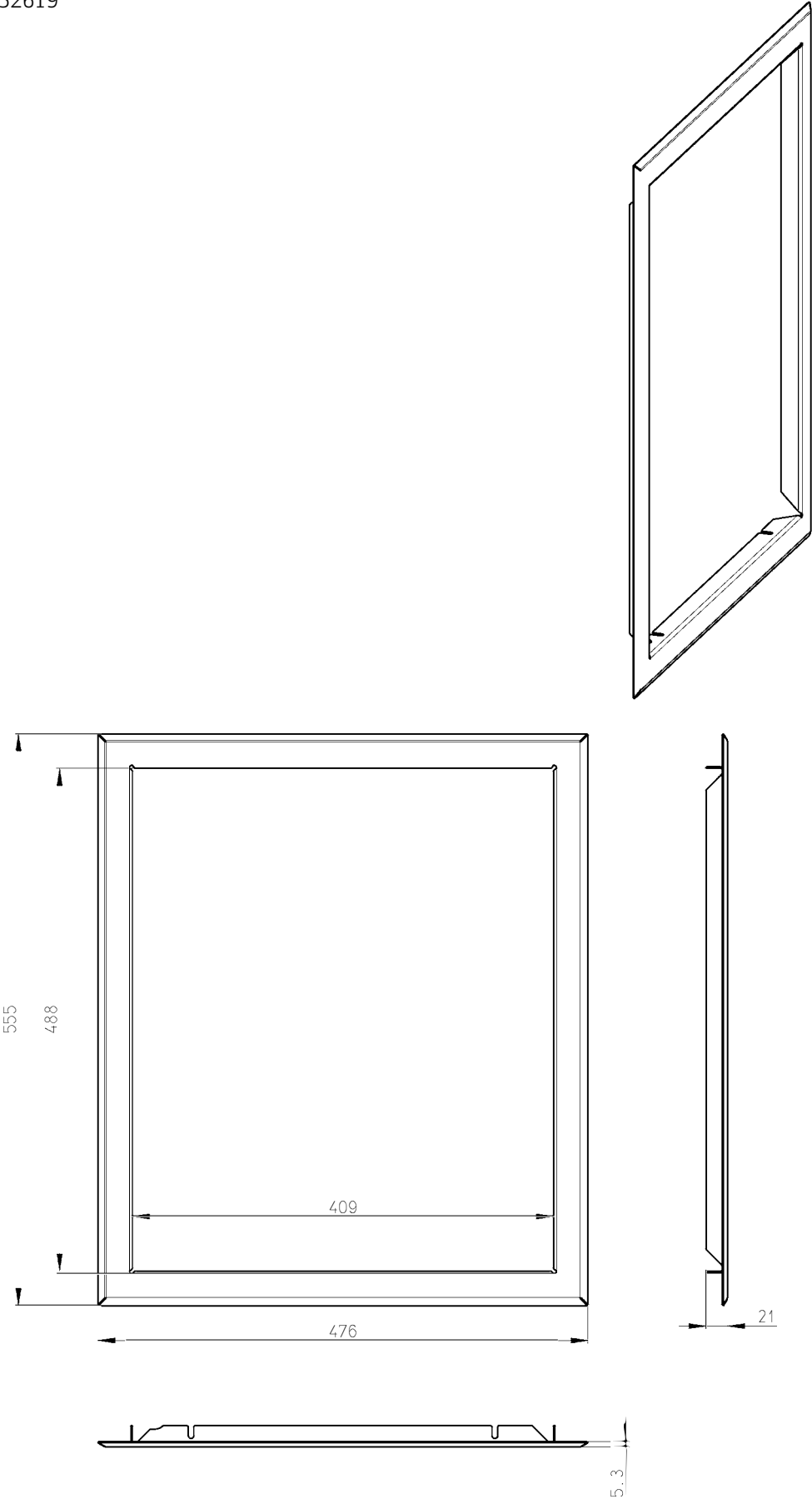

## MOUNTING OF CONVECTION GRATE (ACCESSORY)

---

1

Cut a hole in the wall according to the indicated measures

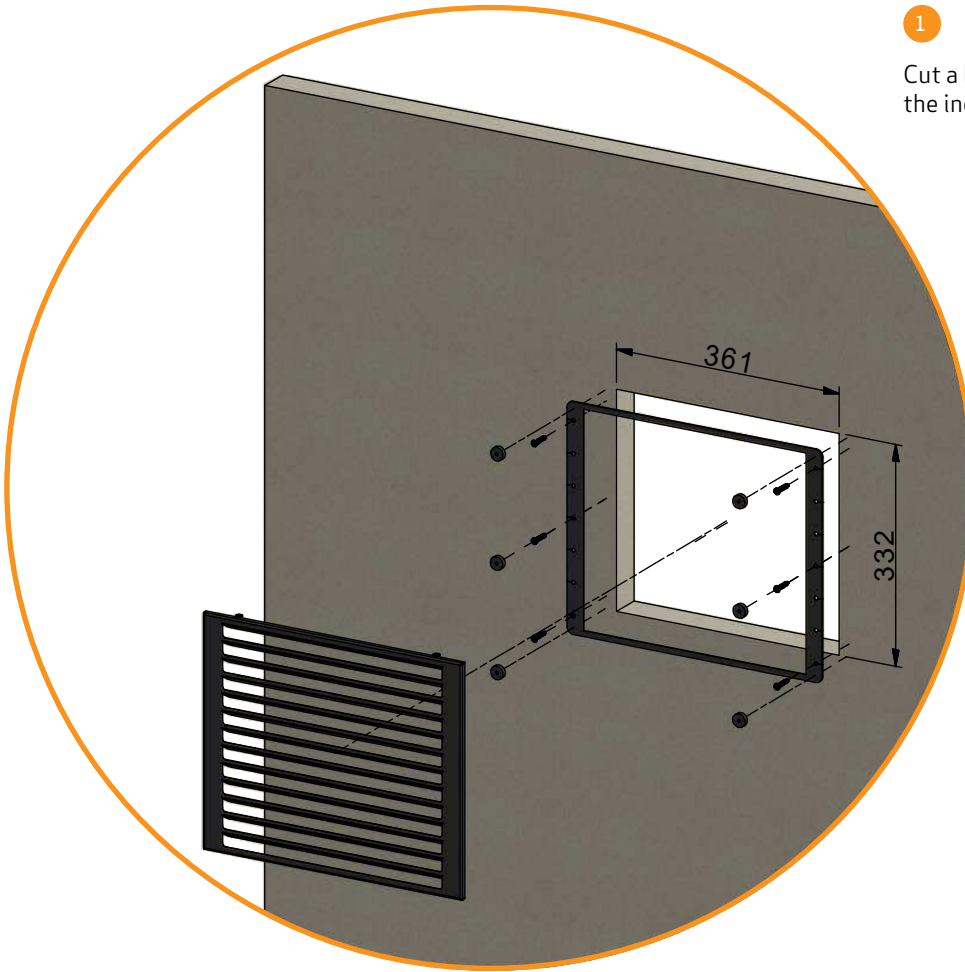

2

Fasten the metal frame with the six screws. Then mount the six magnets on the screws and place the convection grate on the magnets

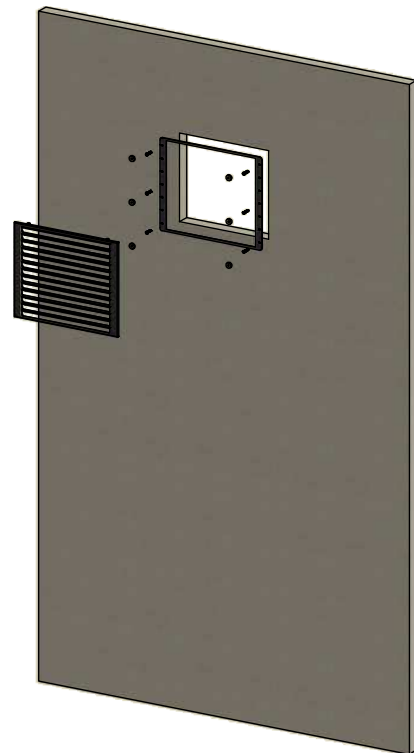

# INSTRUCTIONS FOR USE

## BAFFLE PLATES

---

The baffle plates are located in the upper part of the combustion chamber. The plates hold back smoke, making sure it stays inside the combustion chamber for a longer time before escaping through the chimney. This reduces the flue gas temperature as the gases have more time to dissipate heat to the stove.

The baffle plates must be removed for sweeping; see "Maintaining your built-in stove". Note that the baffle plates are made of porous, ceramic material, and are liable to break easily. You should therefore handle them with care.

*The baffle plates are subject to wear and tear and not covered by the warranty.*

## ASH CONTAINER

---

- Open the door and the grate in the bottom of the stove and lift out the ash container.
- The ash container must not become too full and must therefore be emptied at regular intervals.
- Never empty ashes into a flammable container. Ashes can contain glowing embers long after you finish operating the stove.

## COMBUSTION AIR

---

Combustion air is pre-heated and fed indirectly to the fire. The combustion air flow determines the heat output from your built-in stove. At the same time, the air flow cleans the glass pane to prevent build-up of soot. If there is a soot formation on the glass, this is often due to the fact that the combustion air is turned too much down.

When lighting the fire, the combustion air should be fully open.

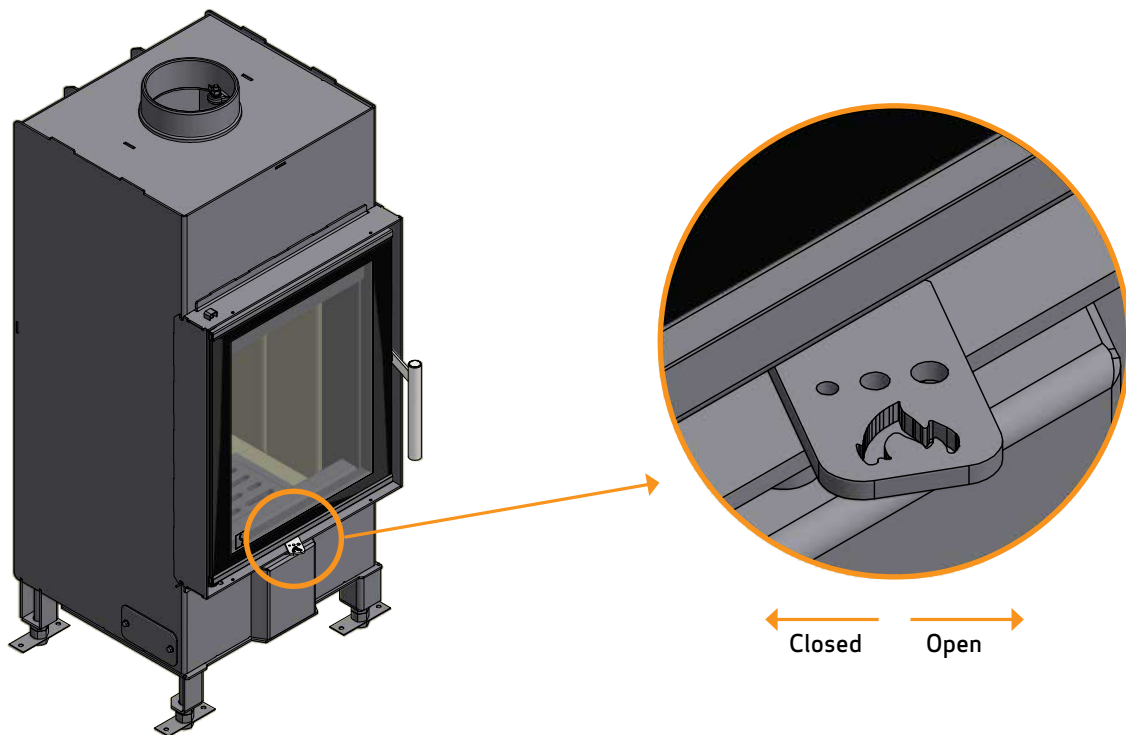

# INSTRUCTIONS FOR HEATING

## ENVIRONMENTALLY FRIENDLY OPERATION

Avoid turning down your built-in stove to the point where no flames are visible from the wood, as this leads to poor combustion and low efficiency. The gases released from the wood will not be burnt off due to the low temperature in the combustion chamber. Some of the gases will condense in the stove and flue system as soot, and this could lead to your chimney catching fire at a later point. The residual smoke which exits the chimney will pollute the surrounding area and cause an unpleasant smell.

### NOTE!

No matter how good your chimney is, it will not perform well, if you do not use it correctly. Equally, a poor chimney may well give you acceptable results, if you use it correctly

## LIGHTING

We recommend the use of fire lighters, or similar products, which are available from your Scan dealer. Using fire lighters helps light the wood more quickly and keeps the combustion process clean.

See our video about correct firing on [www.scan.dk](http://www.scan.dk) or scan the QR-code.

**NOTE: Never use liquid lighting fuels!**

Scan the QR-code and see our video about correct firing.



## "TOP DOWN" LIGHTING

"Top down" lighting is a more environmentally friendly way of lighting the fire and helps to keep the glass area as clean as possible.

Do as follows for a correct "top down" lighting:

- 4 pieces of wood approx. 20-25 cm long with a weight of approx. 0.4-0.5 kg per piece.
- 12-20 thin pieces of firewood of about 20-25 cm in length, with a total weight of approx. 1 kg.
- 3-4 fire lighters.

- 1 Place the pieces of wood, firewood and fire lighters in the combustion chamber as shown below.
- 2 Set the combustion air control to maximum for 20-30 minutes (See "Instructions for use").
- 3 When the large pieces of wood have caught fire, you can adjust the combustion air to the desired level.

**NOTE: The wood must not cover the bottom entirely and must never be placed higher than the indication for max. load (See Maintenance).**



## FIRING IN THE SPRING OR AUTUMN

In the spring/autumn transition period, where there is less need for heating, we recommend you light the stove "top down" once.

## REFUELLING

---

It is important to obtain as high a temperature as possible in the combustion chamber. This results in best possible use of the stove and fuel, as well as achieving clean combustion. In this way you will avoid build-up of soot on the combustion chamber lining and glass pane. During operation, you should not see any smoke; just a movement in the air that indicates combustion is in progress.

- After completing the lighting phase, you should have a good layer of embers in the stove; you can then start operation of it properly.
- Add 2-3 pieces of wood at a time: they should be about 0.5 kg in weight and about 30 cm long.

**NOTE: The wood must catch fire quickly. This is why we recommend setting the combustion air flow fully open.**

**NOTE: Operating the stove at too low a temperature and with too little combustion air can lead to gases igniting, which can damage the stove.**

- When adding wood, always open the glass door carefully to prevent smoke escaping. Never add wood, while the fire is burning nicely.

## WARNING ABOUT OVER-FIRING

---

If the stove is continuously fired with larger amounts of wood than recommended and/or receives too much air, this can cause a heavy heat development liable to damage both stove and the surrounding walls. We therefore recommend that you always observe the max. recommended amount of fuel (See under "Technical Data").

## THE FUNCTION OF THE CHIMNEY

---

The chimney is the built-in stove's motor; its performance determines how well your stove will work. The draught in the chimney creates negative pressure in the wood-burning stove. The negative pressure draws the smoke out of the stove and takes in air through the combustion air damper to fuel the combustion process. Combustion air is also used for the airwash system that keeps the glass clear of soot.

The draught in the chimney is created by the difference in temperature inside and outside the chimney. The higher the difference in temperature, the better the draught. This is why it is important that the chimney reaches operating temperature before you reduce the damper settings to restrict combustion in the stove (a brickwork chimney will take longer to reach operating temperature than a steel chimney). It is very important that the operating temperature is reached as quickly as possible on days when the draught in the chimney is poor due to unfavourable wind and weather conditions. You need to get a few flames going as quickly as possible. Chop the wood extra thin; use an extra fire lighter etc.

- After longer periods without use, you must check the chimney flue for blockages.
- You can connect several units to the same chimney. You should however first check the relevant regulations in this respect.

## USING THE STOVE IN VARIOUS WEATHER CONDITIONS

---

The way the wind affects the chimney can have a big impact on how your stove reacts under various wind loads; you may need to adjust the airflow to achieve good combustion. Fitting a damper in the flue pipe may also help, as it will allow you to regulate the draught under changing wind loads. The damper must not close more than 80% of the flue pipe.

Fog and mist can also have a big impact on chimney draught; you may need to use other settings for the combustion air to achieve good combustion.

## GENERAL NOTES

---

**PLEASE NOTE: parts of the built-in stove, especially the outer surfaces, become hot during use. Due care should be exercised Never place flammable material in the radiation zone of the stove!**

- Never empty ashes into a flammable container. Ashes can contain glowing embers long after you finish operating the stove.
- When the stove is not in use you can close the dampers to avoid a draught through the stove.
- If the stove has not been used for some time, check the flue passageways for potential blockages before relighting.

## CHIMNEY FIRE

---

In the event of a chimney fire, keep the stove door, ash drawer, and all dampers on the stove closed. In an emergency, call the fire service.

- We recommend that you get a chimney sweep to check the chimney before using the stove again.

# HANDLING OF FUEL

## SELECTING WOOD/FUEL

---

You can use any type of wood as fuel. However harder woods, such as beech or ash, are generally better for heating, as they burn more evenly and create less ash. Other woods, such as maple, birch and spruce, are excellent alternatives.

## PREPARATION

---

The best fuel is obtained where the tree has been felled and the wood sawn and split before May 1st. Remember to cut the wood to match the size of the combustion chamber. We recommend a diameter of 6-10 cm. The length should be about 6 cm shorter than that of the combustion chamber to leave enough space for air to circulate. If the diameter of the wood is greater than the above, it should be split down its length. Wood that has been split dries faster.

## STORING

---

You need to store the sawn and split wood in a dry place for 1-2 years before it will be dry enough to burn. Wood dries faster if you stack it in an airy place. Before using it, it is a good idea to store the wood for a few days at room temperature. Remember that wood absorbs moisture from the air during autumn and winter.

## MOISTURE

---

To avoid problematic impact on the environment and to ensure optimum operating economy, the wood should be perfectly dry before it can be used as fuel. If you use wood that is too damp, most of the heat it produces will be used up in evaporating the water. The stove will accordingly not increase in temperature, nor emit heat to the room as a result. This is obviously poor economy, and it will cause soot build-up on the glass pane, in the stove and in the chimney. Operation using moist wood also pollutes the environment.

- Maximum wood moisture content should not exceed 20%. A moisture content of 15-18% will deliver best efficiency.
- An easy way of checking wood moisture content is to knock the ends of the two pieces of wood together. If the wood is moist, the sound will be slightly muffled.

## USE OF THE FOLLOWING AS FUEL IS ILLEGAL

---

**NOTE: It is absolutely prohibited to fire with painted, pressure impregnated or glued wood, or sea driftwood. Nor should you ever burn chipboard, plastics, or treated paper. These contain substances that are hazardous to human health, to the environment, your stove, and your chimney. In short - make sure you only use proper wood.**

## CALORIFIC VALUE OF THE WOOD

---

The various woods have different calorific values. In other words, for certain species of wood, you will need to use a greater quantity to achieve the same heating performance. This Instruction Manual assumes that you will be using beech, which has a very high calorific value and is also the easiest wood to get hold on. If you use oak or beech as fuel, you need to bear in mind that these wood types have a greater calorific value than for example birch. To avoid any risk of damage to the stove, you should therefore make sure to use less fuel in these cases.

Wood types	kg Drywood/m <sup>3</sup>	Compared to beech
Hornbeam	640	110%
Beech/Oak	580	100%
Ash	570	98%
Maple	540	93%
Birch	510	88%
Pine	480	83%
Fir	390	67%
Poplar	380	65%

# MAINTENANCE

## SWEEPING THE CHIMNEY AND CLEANING THE STOVE

Follow national and local regulations for sweeping the chimney. We recommend having the stove cleaned regularly by a chimney sweep.

Before cleaning the stove and sweeping the chimney, the baffle plates must be removed.

**NOTE: All service and repairation must be done, when the stove is cold.**

## CHECKING THE BUILT-IN STOVE

Scan A/S recommends that you check your stove thoroughly after sweeping/cleaning. Check all visible surfaces for cracks. Check that all joints are tight and that the gaskets are correctly seated. Worn or deformed gaskets should be replaced.

## SERVICING

We recommend that the stove is thoroughly serviced at least every two years by a qualified fitter. Remember only to use original spare parts.

**The service should include the following:**

- Lubricate hinges using copper grease.
- Check the gaskets. Replace any that are broken or have turned hart.
- Check the combustion chamber lining and the grate.
- Check heat-insulating materials.

## COMBUSTION CHAMBER LINING

*The combustion chamber lining is not covered by the warranty. The lining consists of the following parts:*

- 11 chamotte plates (1, 3 & 4) ■ 1 grate (2) ■ 2 baffle plates (5 & 7) ■ 2 fittings for baffle plates (6)

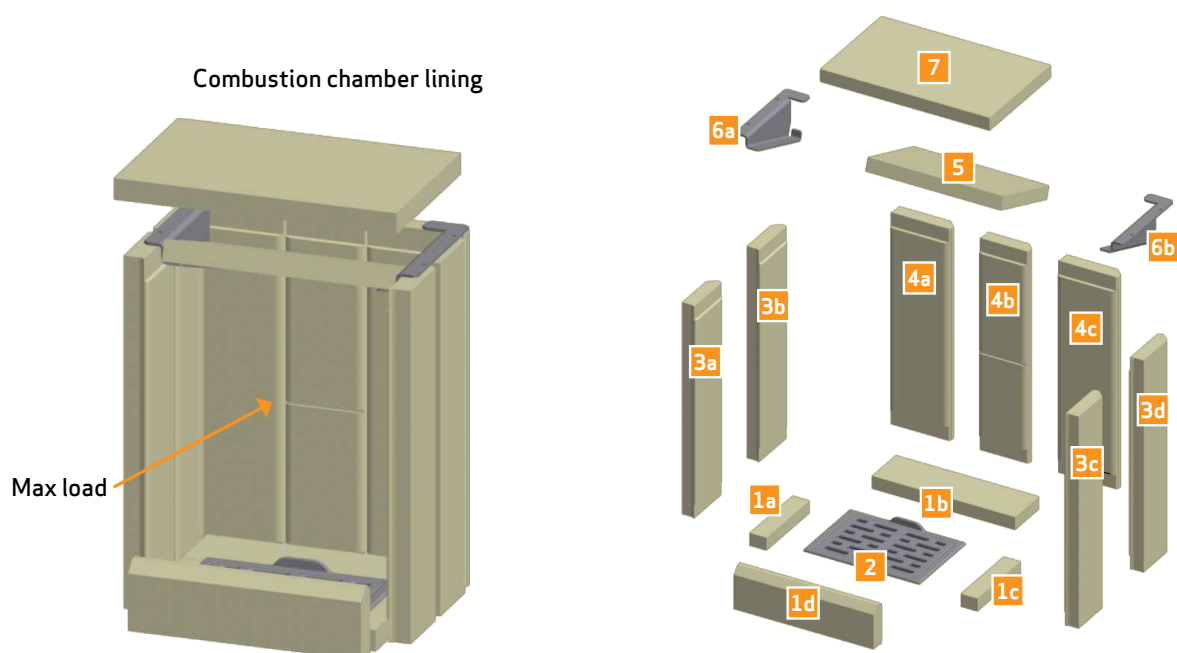

## REPLACEMENT OF THE COMBUSTION CHAMBER LINING

Place the chamotte plate #1 in the bottom.  
Then place the grate #2.

1

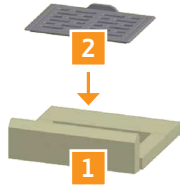

Place the chamotte plates #4a, #4b and #4c.

2



Place the chamotte plates #3a, #3b, #3c and #3d.

3

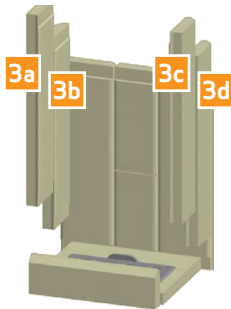

Place the upper baffle plate #7.

4

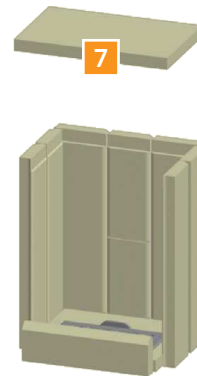

Place the baffle fittings #6a and #6b on the edge of the chamotte plates #3a, #3b, #3c, #3d, #4a and #4c. Then place the lower baffle plate #5. Make sure that the two baffle plates are placed identically.

5

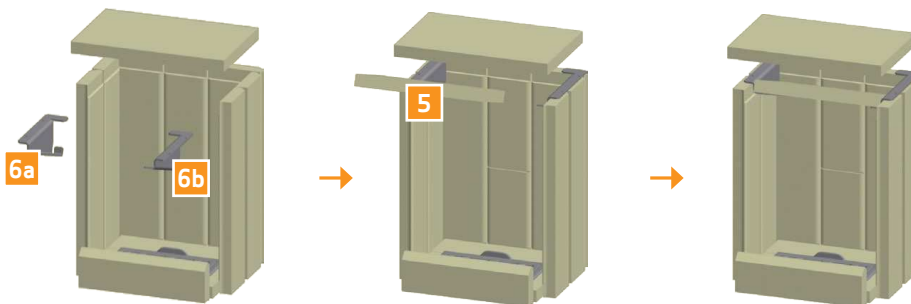

## GASKETS

All stoves have seals made of ceramic material fitted to the stove, the door and/or the glass. These seals are subject to wear and tear and must be replaced when necessary.

*Gaskets are not covered by the warranty.*

## PAINTED SURFACES

Clean your built-in stove by wiping it down with a dry, lint-free cloth.

## CLEANING THE GLASS

---

Our stoves are designed to prevent serious soot build-up on the glass. The best way to achieve this is to make sure you have a good supply of combustion air. It is also very important that the wood is dry and the chimney correctly dimensioned.

Even if you operate the stove in accordance with our instructions, a slight film of soot may still accumulate on the glass. You can easily remove this film by wiping the glass down with a dry cloth and then with a cloth dampened with glass cleaner.

- Please note that the glass cleaner is not to get into contact with the gaskets, as this can discolour the glass permanently.
- The glass cleaner must not come into contact with the painted surfaces, as these can be damaged.

## DISPOSAL OF STOVE PARTS

---

Steel/cast iron	Send for recycling
Glass	Dispose of as ceramic waste
Combustion chamber lining	Vermiculite and chamotte are not recyclable. Dispose of as waste.
Baffle plates	Vermiculite and chamotte are not recyclable. Dispose of as waste.
Gaskets	Dispose of as waste

# TROUBLESHOOTING

## SMOKE ESCAPING

---

- Damp wood
- Chimney is not properly dimensioned for the stove
- Is the chimney the right height for its surroundings?
- At rear outlet, check that the flue pipe does not obstruct the chimney draught
- Chimney not drawing properly
- Check if the smoke gas pipe/chimney are blocked
- Vacuum in the room
- The door is opened before the embers have burned down sufficiently

## WOOD BURNING TOO QUICKLY

---

- The air valve are set incorrectly
- Inferior firewood (wast wood, pallets etc.)
- The baffle plates are incorrectly mounted or missing
- Too much chimney draught

## SOOT BUILD-UP ON GLASS

---

- Incorrect secondary airflow setting
- Damp wood
- Inferior firewood (waste wood, pallets etc.)
- Vacuum in the room
- Excessive primary air
- Wood pieces too large for lighting
- Chimney not drawing sufficiently

## EXCESSIVE SOOT BUID-UP IN CHIMNEY

---

- Poor burning (more air is required)
- Damp wood

## THE SURFACE OF THE STOVE IS TURNING GREY

---

- Over-firing (See "Instructions for heating")

## POOR HEATING PERFORMANCE OF STOVE

---

- Damp wood
- Inferior wood quality with low calorific value
- Not enough wood
- The baffle plates are not fitted correctly

## SMELL AND SOUND OF THE STOVE

---

- The lacquer on the stove hardens, when you use the stove for the first time; this can cause an odour. Open a window or a door for ventilation and make sure that the stove is heated up sufficiently to avoid odours later.
- When heating up and cooling down, the stove may make some clicking noises. These are due to the huge temperature differences to which the material is exposed and do not indicate any product defects.

# WARRANTY

All wood-fired Scan products are made of high-quality materials and subject to strict quality controls before leaving the factory. We give a warranty of 5 years on manufacturing errors or defects.

You must quote your stove's product registration number when you contact us or your authorised Scan dealer with a warranty claim.

The warranty covers all parts which in the opinion of Scan A/S require repair or replacement due to manufacturing or construction error

The warranty applies to the original purchaser of the product only, and is not transferable (except on prior sale).

The warranty covers only damage caused by manufacturing or construction errors.

## THE FOLLOWING PARTS ARE NOT COVERED BY THE WARRANTY

---

- Wear and tear parts, such as the combustion chamber liners, baffle plates, riddling grate, glass, and seals (except for defects which were present on delivery).
- Defects caused by external chemical and physical influences during transportation, storage and assembly, or at a later time.
- Soot build-up caused by poor chimney draught, damp wood, or improper use.
- Costs of additional heating in connection with a repair.
- Transport costs.
- Costs for setting up or removing the wood stove.

## THIS WARRANTY IS VOID

---

- In case of incorrect installation (the installer is responsible for observing and complying with legal requirements and local bylaws, along with this Assembly- and Instructionsmanual for the wood-burning stove and accessories).
- In case of improper use, and/or use of prohibited fuels, non-original spares (see this Assembly- and instructions manual).
- If the product registration number of the stove has been removed or damaged.
- In case of repairs that do not comply with our instructions or instructions by an authorised Scan dealer.
- In case of any manipulation of the original state of this Scan product or its accessories.
- This warranty is only valid in the country to which this Scan product was originally supplied.





Product registration number

Quote this number at all enquiries